

SIMULATION AND MONITORING OF THE MACHINING PROCESS VIA FUZZY LOGIC AND CUTTING FORCES

A. Salimi^{1*}, A. Özdemir² and A. Erdem³

* salimy@pnu.ac.ir

Received: March 2015

Accepted: May 2015

¹ Department of Mechanical Engineering, Payame Noor University, Tehran, Iran.

² Manufacturing Engineering Department, Faculty of Technology, University of Gazi, Ankara, Turkey.

³ Computer Engineering Department, Faculty of Technology, University of Gazi, Ankara, Turkey.

Abstract: On time replacement of a cutting tool with a new one is an important task in Flexible Manufacturing Systems (FMS). A fuzzy logic-based approach was used in the present study to predict and simulate the tool wear progress in turning operation. Cutting parameters and cutting forces were considered as the input and the wear rate was regarded as the output data in the fuzzy logic for constructing the system. Flank wear was used as the tool life criterion and the wear ranges were selected between 0 and 0, 3 based on ISO 3685 standard for new and worn tool respectively. For conducting the tests, Taghuchi method was used to design an experimental table. The results of the measurements and estimates confirmed the reliability of the fuzzy logic method for estimating tool wear. One significant feature of the proposed system is that it can predict the wear rate on-line by transferring the cutting force signals from the sensor to the fuzzy logic simulation box.

Keywords: Tool condition monitoring, cutting forces, fuzzy logic, simulation

1. INTRODUCTION

At the present time, the manufacturing companies are required to produce high-quality and low-cost products in the shortest time so that they can compete with others in the global markets [1]. To fulfill this aim in the machining processes, automation is considered to be a significant issue for manufacturers [2]. To establish an automatic machining system, manufacturers are obliged to develop a reliable and strong monitoring system. Hence, the creation of automation system enhanced the significance of tool condition monitoring in machining operations among researchers. In addition to the dead time and the costs resulting from the replacement of a worn tool with a new one, real time monitoring of the tool wear is needed to prevent losses that may occur during tool breakage and machining with a worn tool [3].

Many questions and concerns are involved within the issue of constructing a tool condition monitoring system in machining operations; that is, questions such as sensor selection system, multi sensor detector [4,1,5], signal processing and feature extraction [3,6], designing issues in

the related experiments [7,8] and process modeling by using intelligent systems are investigated by related researchers [1,9]. Although many studies have been conducted in this research domain, researchers have not been able to develop and design a sound method yet and many studies have been dedicated to on-line monitoring of tool conditions, optimization of machining processes, control and prediction.

In general, tool wear monitoring methods can be classified into two categories, namely direct and indirect methods. In direct methods, it is possible to determine tool wear directly. In other words, these methods can really measure the tool wear directly from the inserts. However, despite the development of several direct methods such as visual inspection, computer vision, etc, they are not regarded as promising and favorable methods of monitoring tool conditions; in particular, these methods are not economical and technical [10]. Over the years, indirect methods of estimating tool wear have become increasingly popular. Indirect methods are based on variables which change along with the machining processes. Many variables can be considered with regard to the machining region, i.e., cutting force, vibration, acoustic emission, sound,

temperature, surface quality and etc. All these variables can be affected by the cutting tools and machining conditions [11]. In order to monitor tool conditions, researchers should consider all the effective variables using physical sensors, After processing the received signal from the sensors, the signal features are determined and extracted based on the processing conditions. At the final diagnosis stage, the received data are sent to the decision support systems (DSS). The decision support systems can apply to predict and classify input data in different fields of sciences. Many prediction systems have been created using of fuzzy logic or artificial neural networks and etc in various scientific fields [12,13]. After designing the decision support system, the results are received and are sent to the operator and machine tools to make the required decision about the machining process. Seven steps should be taken for creating a tool condition monitoring system: (1) an appropriate sensor should be selected for measuring the variables (2) received signals should be processed (3) the monitoring scope should be specified (4) the most effective features should be selected (5) features are extracted (6) experiments are designed (7) a decision support system is selected [1,11].

Effective and efficient monitoring of tool conditions in industry highly depends on robust and reliable sensor signals such as force, power and AE. They are relatively easy to install in existing or new machines and do not affect machine integrity and stiffness. Recent studies indicate that force signals can be considered as the most useful data for determining tool conditions [14,15].

In this study, cutting force was used for monitoring tool wear condition in turning

operation. Fuzzy logic system was used for constructing the prediction system. Furthermore, flank wear was used as the tool life criterion which ranged from 0 to 0, 3 respectively, based on ISO 3685 for the new and worn tool. Cutting parameters and cutting forces were regarded as the input and the wear rate was considered as the output in the proposed fuzzy logic system. The data was used and a simulation box was created to get the signals directly from the sensor. Then, the wear rate was predicted on-line and immediately. The obtained results confirm the reliability of the fuzzy logic method for simulating and predicting tool wear.

2. EXPERIMENTS

In this paper, prediction and simulation of the tool wear was carried out by using cutting parameters and cutting force. Johnford TC-35 CNC machine tool was used to perform the experiments. A Sandvik- Coromant insert (TNMG 1604-QM H13) was selected as the cutting tool along with a TIZIT Simple (CTANR 2525M16) marked tool holder. The material used for machining was SAE 1050 with Ø100×1000 mm of dimension. Chemical Compositions of the work piece are given in Table1. The cutting parameters used for machining operation were selected based on ISO 3685 Standard (Table.2). A Dino Capture microscope was used to measure the flank wear rate of the cutting tools. Cutting Forces were measured by using a Kistler 9272 4-component dynamometer and Kistler 5070Ax01xx amplifier in three direction including Fc (cutting force), Ft (thrust force) and Fr (radial force). The data regarding cutting forces were recorded in a computer using 4-

Table.1 Chemical Compositions of the work piece

Work piece	SAE1050(AISI1050)							
Chemical compositions (%)	C	Si	Mn	Cr	P	S	Mo	N
	0.49	0.19	0.65	0.03	0.01	0.005	0.01	0.08

Table 2. Cutting parameters

Cutting speed (m/min)	Feed rate (mm/rev)	Cutting depth (mm)	Flank wear ranges (mm)
100	0.18	1	0-0.1-0.2-0.3
125	0.23	1.5	
150	0.28	2	

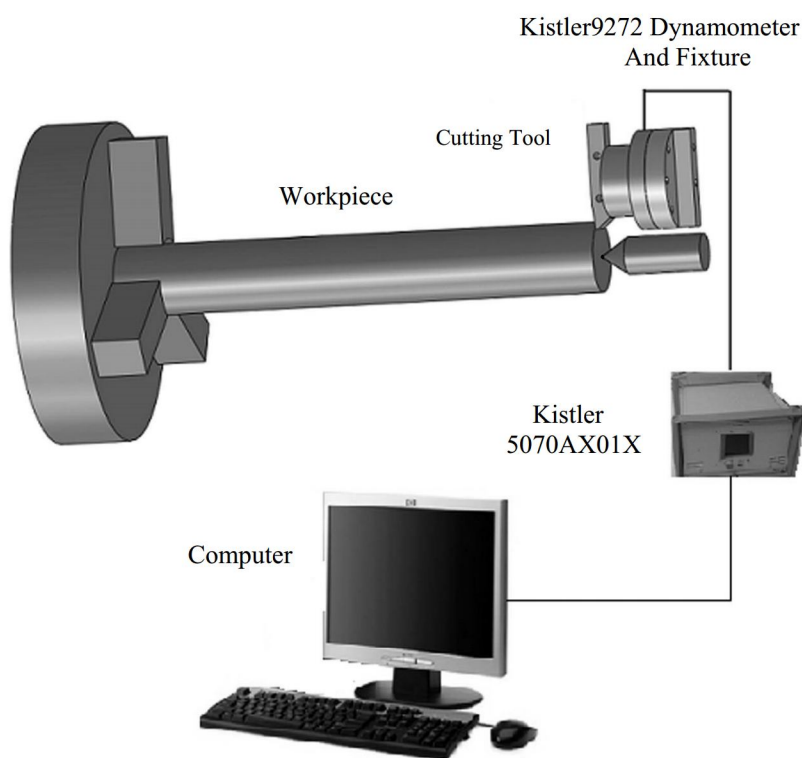

Fig. 1. Experimental setup

channel 5070Ax01xx amplifier. The range for tool wear was selected between 0- 0. 3 for a new and worn tool respectively based on ISO3685 standard. Fig.1 shows the experimental setup for performing the tests.

3. EXPERIMENT PROCEDURE

For establishing a tool wear prediction system,

the wear ranges were selected as: 0; 0. 1; 0.2; 0.3 for a new, relatively worn, highly worn and worn out tool. Using the cutting parameters and Taghuchi method, the researchers created an L9 (33) experimental array for conducting the tests. By applying the wear ranges, a total of 36 experiments were carried out to measure the magnitude of cutting force during the machining process. Indeed, there are three forces in the

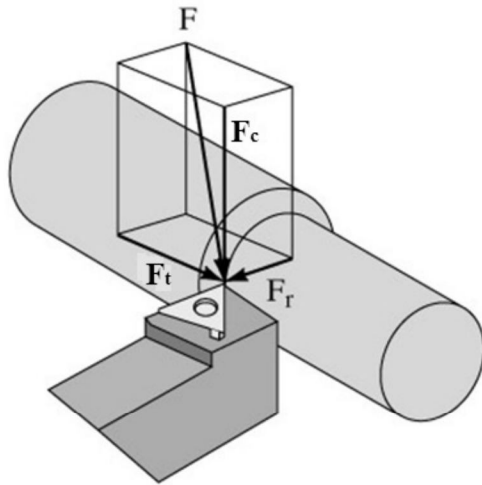

Fig. 2. The 3-axial force applying on the tool tip

machining area which result from the metal cutting process (Fig.2). To design a reliable prediction system, the researcher considered all the three components of the forces . The value of the resultant force is obtained by the following equation:

$$F = \sqrt{F_c^2 + F_t^2 + F_r^2} \quad (1)$$

4. FUZZY LOGIC

Fuzzy logic is a computing method which is based on the "degrees of truth" rather than the usual "true or false". The basic idea behind fuzzy logic was first advanced by Dr. Lotfi Zadeh at the University of California in Berkeley in the 1960s. Fuzzy logic includes 0 and 1 as the extreme cases of truth and includes various states of truth in between. For example, the result of a comparison between two things could be stated in terms of the percentage or degree of tallness rather than the all-inclusive and imprecise states of "tall" or "short". Fuzzy logic can be considered as a generalization of the classical logic. Problems which are based on imprecise data and in which very general rules of inference are formulated

make use of diffuse categories. The model of fuzzy logic is easy to understand and can incorporate new knowledge smoothly. In the past, significant theoretical results and outcomes have been achieved in the field of fuzzy logic systems. Many researchers have acknowledged the fact that a fuzzy logic system can uniformly approximate any real continuous nonlinear function to an arbitrary degree of accuracy [16]. Also, fuzzy logic systems have two other outstanding advantages. That is, they use existing linguistic knowledge very successfully and they treat uncertainty most appropriately and properly[16].

5. FUZZY INFERENCE SYSTEM (FIS)

Using fuzzy rules, a fuzzy inference system essentially defines a nonlinear mapping of the input data vector into a scalar output. The mapping process involves input/output, membership functions, fuzzy logic (FL) operators, fuzzy if-then rules, aggregation of output sets, and defuzzification. There are two types of fuzzy inference systems namely, Mamdani-type and Sugeno-type. Although there are many inference systems that can be applied in fuzzy logic modeling, however two of them (Mamdani and Sugeno) are supported by MATLAB software. These two types of inference systems differ from each other in the way they determine outputs. Mamdani's fuzzy inference method is the most commonly used fuzzy methodology [17]. The Mamdani's method was used as an FIS in this paper. Figure 3 shows a general model of a fuzzy inference system. As shown in this figure, it can be noted that FIS consists of four components: the fuzzifier, inference engine, rule base and defuzzifier.

6. FUZZIFICATION

The fuzzification refers to the process of transforming crisp values into grades of membership with respect to the linguistic terms of fuzzy sets. In other words, fuzzifier takes input values and determines the degree to which they belong to each of the fuzzy sets via membership functions; this is required in order to activate

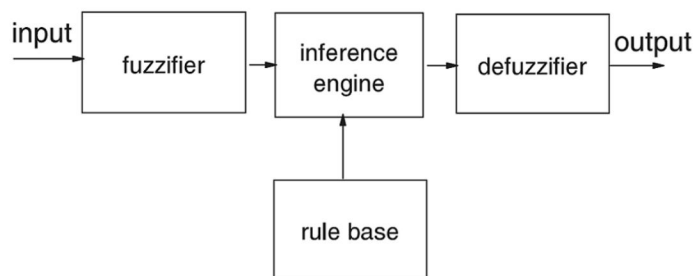

Fig. 3. The general model of a fuzzy inference system

rules in terms of linguistic variables. The membership function is used to associate a grade to each linguistic term.

For each of the selected input and output variables, two or more membership functions (MF) and a qualitative category such as low, normal or high are defined. The shape of these functions can be diverse ranging from triangles, trapezoids, etc. In choosing the membership functions for fuzzification, the event and type of membership functions are mainly dependent upon the relevant event.

7. INFERENCE ENGINE

The inference engine defines mapping from input fuzzy sets into output fuzzy sets. It determines the degree to which the antecedent is satisfied for each rule. If the antecedent of a given rule has more than one clause, fuzzy operators will be applied to obtain a number that represents the result of the antecedent for that rule. It is likely that one or more rules may fire at the same time.

8. FUZZY RULE BASE

Fuzzy rules are regarded a set of linguistic statements which establish the relationship between the input and output in a fuzzy system. They are defined based on experimental work. The number of fuzzy rules in a fuzzy system is related to the number of fuzzy sets for each input variable. The “and” and “or”

used in the rules will apply to the fuzzy “and” and “or” operations, respectively.

9. DEFUZZIFICATION

Outputs for all rules are aggregated. During aggregation, fuzzy sets that represent the output of each rule are combined into a single fuzzy set. In other words, defuzzification is the conversion of a fuzzy quantity to a precise value, just as fuzzification is the conversion of a precise value to a fuzzy quantity. Researchers make use of seven methods which are available in the literature for defuzzifying; they include: centroid, weight average, mean of max, center of sum, center of the largest area, first (or last) of maximum method. The selection of method is of high significance since it greatly influences the speed and accuracy of the model. Among the above-methods, centroid, when compared with other methods, has considerable acceptance and capability in giving more accurate results [18]. In this method, the resultant membership functions are developed by considering the union of the output for each rule which means that the overlapping area of fuzzy output set is counted as one; hence, it provides more results [19,20].

10. FUZZY LOGIC MODELING

All the previously mentioned steps should be respectively taken into consideration in order to create a fuzzy logic model. To illustrate the calculation method in Matlab program, the

researchers evaluated the analytical estimation procedure as an example by using of a single set of real data. In order to fuzzify the input and output data in this paper, the researcher checked all the membership functions in Matlab and used the most precise one for these data. When compared with other methods, Gaussian family methods had the most accurate results. The Gaussian-based membership function is defined by a central value m and a standard deviation $k > 0$ as illustrated below (Fig.4):

$$\mu(x) = e^{-\frac{(x-m)^2}{2k^2}} \quad (2)$$

Based on the fuzzy sets defined for input variables (Fig.5 to Fig.8) and output variables (Fig.9), the rules are written as follows:

If feed rate is f_2 and cutting depth is d_2 and cutting speed is V_2 and cutting force is F_1 , then the tool wear will be w_1

If feed rate is f_2 and cutting depth is d_2 and cutting speed is V_2 and cutting force is F_2 , then the tool wear will be w_2

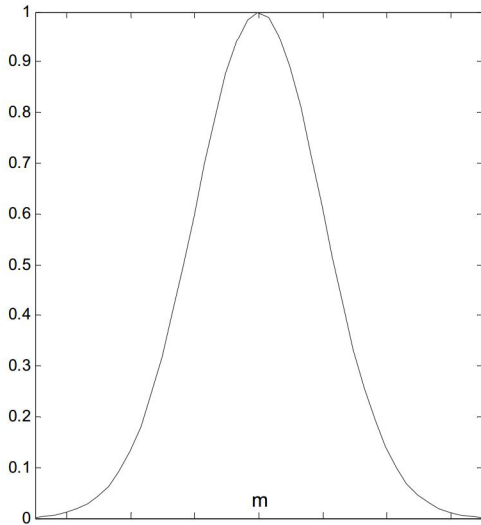

Fig. 4. Gaussian membership function

If feed rate is f_2 and cutting depth is d_2 and cutting speed is V_2 and cutting force is F_3 then the tool wear will be w_3

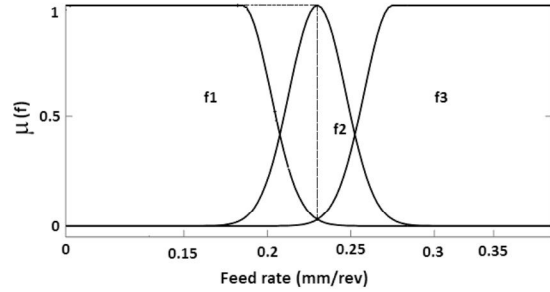

Fig. 5. Membership functions of input feed rate

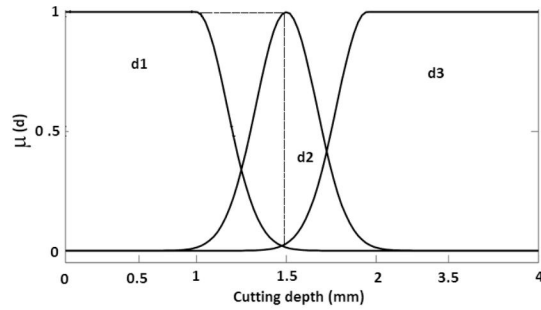

Fig. 6. Membership functions of input cutting depth

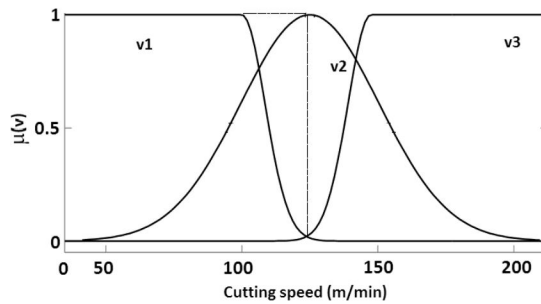

Fig. 7. Membership functions of input cutting speed

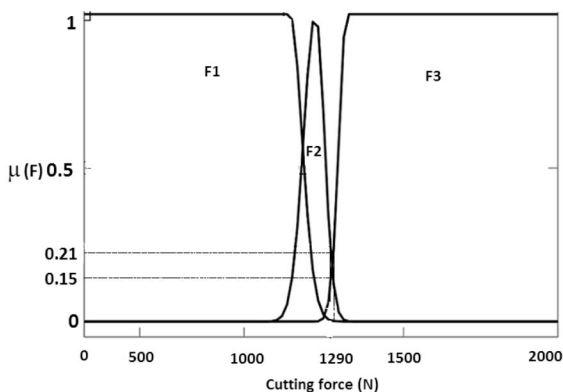

Fig. 8. Membership functions of input cutting forces

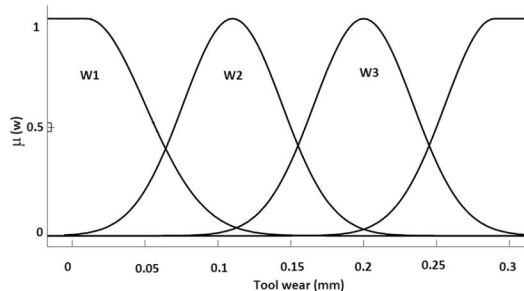

Fig. 9. Membership functions of output tool wear

Having written the rules, the researcher can use the fuzzy logic system to estimate the results. As an example, for the feed rate of 0.23 mm/rev, cutting depth of 1.5 mm and cutting speed of 100 m/min, the measured cutting force and tool wear were respectively 1290 N and 0.163 mm. By using of the above three rules and the given data, the wear rate can be obtained mathematically. All the data are fuzzified by using equation (2) as follow:

$$\mu(f_2=0.23)=1, \mu(d_2=1.5)=1, \mu(V_2=100)=1, \\ \mu(F_2=1290)=0.15, \mu(F_3=1290)=0.21$$

Based on the “AND” operator, method of estimating the degree of membership functions for any outputs is calculated as follows:

- Rule 1: $\mu(w_1)=0$
- Rule 2: $\mu(w_2)=0.15$
- Rule 3: $\mu(w_3)=0.21$

All the above-mentioned calculated degrees of membership functions are fuzzy values and imply the real values of the tool wear. For obtaining the real values of the tool wear, defuzzification is required. Before defuzzification, all the outputs

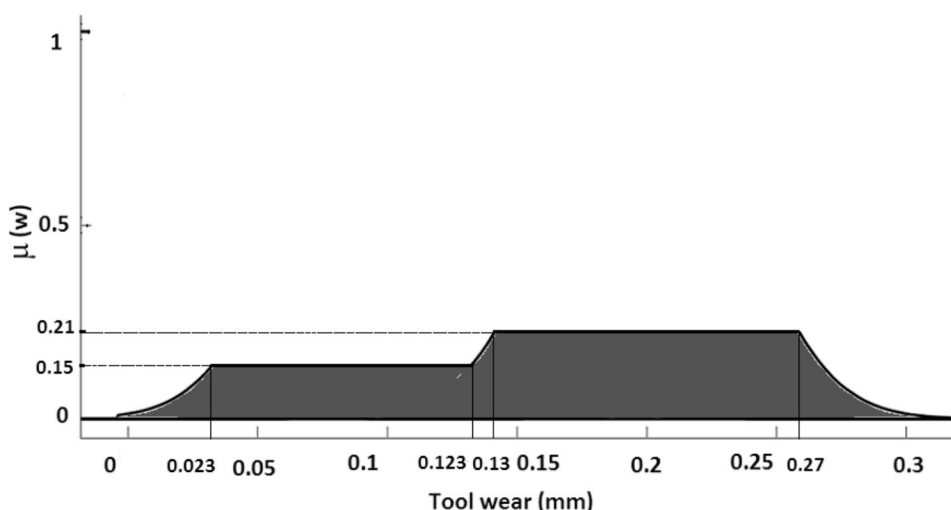

Fig. 10. The aggregated outputs of the rules

are aggregated to a single fuzzy set as is seen in Fig.10. After aggregation of the fuzzy sets, the fuzzy values were defuzzified. In this paper, the centroid method was used for defuzzification of the fuzzy values. The equation for the centroid method is the following:

$$Output = \frac{\int_a^b \mu(w)wdw}{\int_a^b \mu(w)dw} \quad (3)$$

In this equation, w is the real value of the wear, $\mu(w)$ is the degree of membership function of the wear and a and b constants are the intervals of the definite integral. By applying equation (3) for Fig.10, the real value of the tool wear was estimated as follows:

The measured tool wear rate for this rule was 0.163 mm. Comparing the estimated and measured values reveal that there is a considerable agreement between them.

11. PREDICTION SYSTEM OF THE FUZZY LOGIC

In this paper, Matlab Fuzzy logic tool box was used to develop the prediction system. For creating the fuzzy logic system, four inputs including cutting speed (V), cutting depth (d), feed rate (f) and resultant cutting forces (F) were regarded as the input of the fuzzy logic and the tool wear was selected as the output. By using the Mamdani’s method, the system was created as in Fig.11.

As it was mentioned above, there were three cutting parameters and three respective levels were considered for each of the parameters. Therefore, three sets were selected for each of cutting parameters as the inputs. Regarding the cutting force, 36 fuzzy sets were assigned based on the number of experiments in which all the measured force values were different. On the other hand, four fuzzy sets were assigned for the four levels of the wear variable, i.e. 0, 0.1, 0.2 and 0.3 mm. These sets were used to fuzzify the

$$\mu(w) = \frac{\int_0^{0.023} w e^{-\frac{(w-0.1)^2}{0.0032}} + 0.1 \times 0.15 \times 0.73 + \int_{0.123}^{0.13} (w + 0.123) e^{-\frac{(w-0.2)^2}{0.0032}} + 0.14 \times 0.21 \times 0.2 + \int_{0.27}^{0.3} (w + 0.27) e^{-\frac{(w-0.2)^2}{0.0032}}}{\int_0^{0.023} e^{-\frac{(w-0.1)^2}{0.0032}} + 0.1 \times 0.15 + \int_{0.123}^{0.13} e^{-\frac{(w-0.2)^2}{0.0032}} + 0.14 \times 0.21 + \int_{0.27}^{0.3} e^{-\frac{(w-0.2)^2}{0.0032}}}$$

= 0.161mm (10.3)

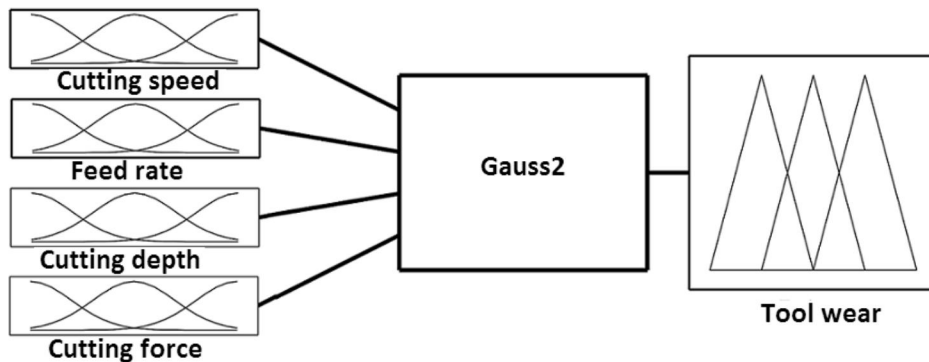

Fig. 11. Fuzzy logic model designed for tool wear simulation

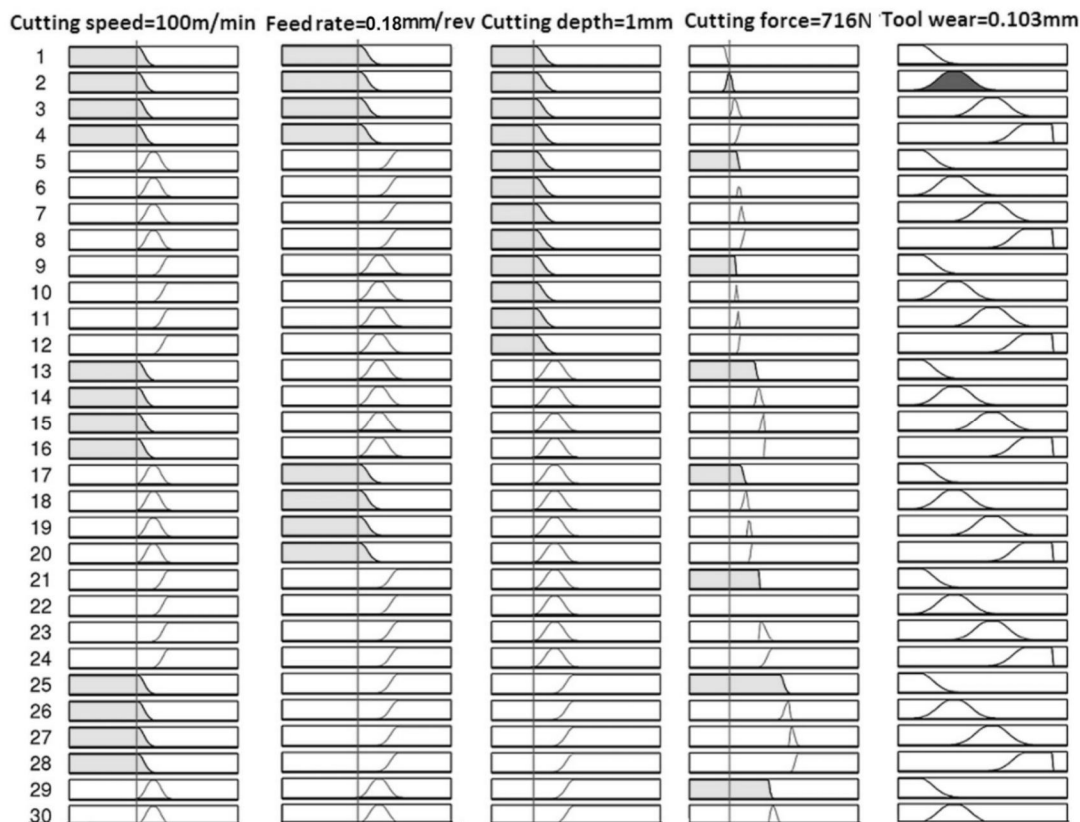

Fig. 12. The fuzzy logic inference system for predicting the wear rates

output values. Based on the experiments and fuzzy sets, 36 rules were written to create the inference engine. Fuzzy logic inference system is given in Fig.12. Tool wear rate is estimated and predicted by entering the input values in this system. Changing the cutting parameters in the input of the fuzzy system will make a change in the tool wear rate to predict the wear rate. With respect to the inputs, cutting force variables are assumed to have the major role for identifying the wear rates and any variations in the cutting forces will change the tool wear rate. This is due to the fact that, for constant values of the cutting parameters, the cutting forces are enhanced during the machining process; such an increase in the cutting force results from an inevitable tool wear.

12. RESULTS AND DISCUSSION

A fuzzy logic system was designed in the present study to predict and simulate the tool wear event during the machining process. The impetus behind this research study was to use the cutting force for online monitoring and online prediction of the tool wear. The relationship between the tool wear and cutting force which was obtained from the fuzzy inference system is given in Fig.13.

As it is clearly illustrated in the Figure above, any changes in cutting force rates result in a dramatic variation in tool wear rate. Moreover, based on variations in cutting force, it can be observed that there is approximately a %70 increase in the cutting force of a new and worn-out tool. Therefore, the cutting force can be considered as the most effective variable for tool

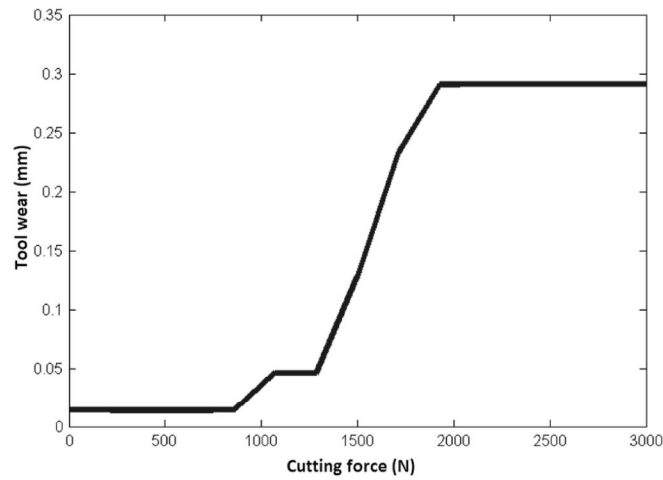

Fig. 13. The relationship between the tool wear and cutting force for cutting speed: 125m/min, feed rate: 0.2mm/rev and cutting depth: 2mm

wear prediction. As Fig.13 depicts, the tool wear rate graph has a constant value until the cutting process starts and continuing the machining operation will enhance the cutting forces and the tool wear directly. The increase in tool wear continues until the wear rate reaches 0.3 and the tool should be replaced with a new one. At this time and for these cutting parameters, the wear changes stop since the machining process must be stopped. In this system, the most important role of the cutting parameters is to change the

cutting force only for a new tool; however, after starting the cutting operations, their effects on the cutting force and tool wear rate decrease. Thus, in order to establish a prediction system, a dynamometer for tool wear estimation should be sufficiently used since the cutting force and tool wear follow each other during the operation. In order to simulate the tool wear with respect to the machining process, the researcher created a simulated box in Matlab Simulink Tool Box. As shown in Fig.14, the cutting parameters and the

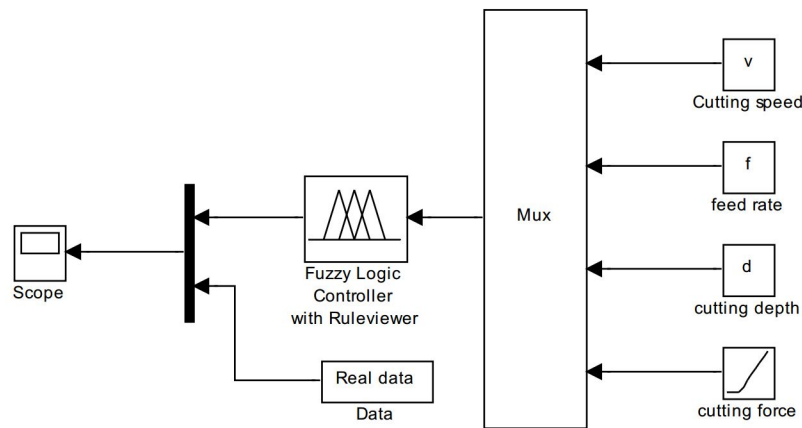

Fig. 14. The simulation of the prediction system for the tool wear

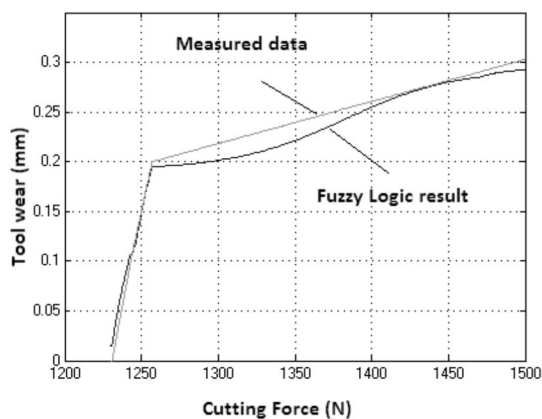

Fig. 15. The comparison of the tool wear during the machining operation where cutting speed: 150 m/min, feed rate: 0.28 mm/rev and cutting depth: 1,5 mm

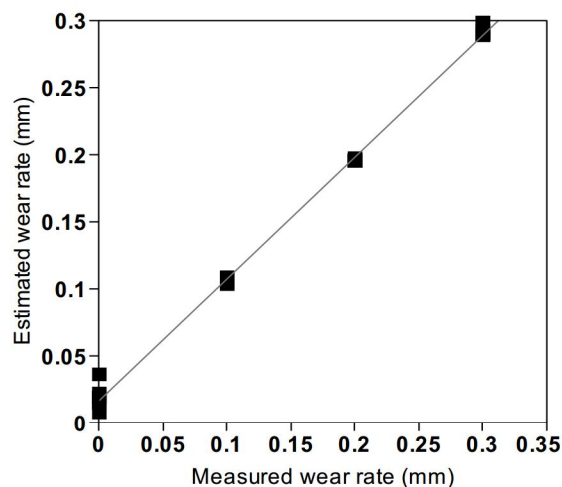

Fig. 16. Comparison of the measured and estimated wear rates by fuzzy logic.

cutting force transition model are given in this simulation box and the tool wear rate changes online and immediately as the input values change.

If a dynamometer instead of the analytical model is used to take the cutting force, the system can be used as an online monitoring system to predict the real data. The simulation result is given in Fig.15 for both the measured and estimated wear rates. As it can be noted clearly from the graph, the designed fuzzy system can accurately follow the measured data. The measured tool wear and the tool wear estimated from the fuzzy system were compared with each other for all the experiments. Fig.16 shows the results of the comparison in which the value of R^2 obtained for this simulated system is about 0.997.

13. CONCLUSION

In the present study, a fuzzy logic system was designed. The results revealed that fuzzy logic is a strong and reliable tool for predicting nonlinear events such as tool wear rate in the machining operations. Moreover, it was found that online monitoring of the tool wear rate is possible by creating a simulation box of the fuzzy logic system where the signals are taken from a sensor and transferred to the designed simulation box.

The system gets the cutting force signals and estimates the wear rates immediately and online during the machining operation. This method has an advantage which makes it more efficient and effective than the other tools. That is, working with a fuzzy logic for a certain number of experiments is easy and practical. For example, there is no need to conduct a lot of unnecessary tests and researchers need to work only with a limited number of cutting parameters. Researchers can easily apply this method in their work shop by using a dynamometer. Also, application of the fuzzy logic in adaptive control regarding machine tools and machining processes can be considered as another remarkable feature for the fuzzy logic systems. Applying the fuzzy logic for adaptive control in machining processes will be the subject of future research for the researchers of the present study.

ACKNOWLEDGMENT

The authors are very pleased to acknowledge that the work was supported by the Gazi University, Department of Scientific Research Project (Project Number 07/2012-23)

REFERENCES

1. Liang, S. Y., Hecker, R. L., Landers, R. G., "Machining process monitoring and control: The state-of-the-art". *J Manuf Sci E-T Asme* 2004, 126 (2):297-310. doi:10.1115/1.1707035
2. Abellan-Nebot, J., Romero Subirón, F., "A review of machining monitoring systems based on artificial intelligence process models". *The International Journal of Advanced Manufacturing Technology*, 2010, 47 (1):237-257. doi:10.1007/s00170-009-2191-8
3. Guyon, I., Elisseeff, A., "An introduction to variable and feature selection". *J Mach Learn* 2003, Res 3:1157-1182
4. Cho, D. W., Lee, S. J., Chu, C. N., "The state of machining process monitoring research in Korea". *International Journal of Machine Tools and Manufacture*, 1999, 39 (11):1697-1715. doi:10.1016/s0890-6955(99)00026-7
5. Bahr, B., Motavalli, S, Arfi, T (1997) Sensor fusion for monitoring machine tool conditions. *International Journal of Computer Integrated Manufacturing* 10 (5):314-323. doi:10.1080/095119297131066
6. Ertekin, Y.M., Kwon, Y, Tseng, T-L (2003) Identification of common sensory features for the control of CNC milling operations under varying cutting conditions. *International Journal of Machine Tools and Manufacture* 43 (9):897-904. doi:10.1016/s0890-6955(03)00087-7
7. Zhang, J. Z., Chen, J. C., "The development of an in-process surface roughness adaptive control system in end milling operations". *International Journal of Advanced Manufacturing Technology*, 2007, 31 (9-10):877-887
8. Benardos, P. G., Vosniakos, G. C., "Prediction of surface roughness in CNC face milling using neural networks and Taguchi's design of experiments". *Robotics and Computer-Integrated Manufacturing*, 2002, 18 (5-6):343-354
9. Niu, Y., Wong, Y., Hong, G. "An intelligent sensor system approach for reliable tool flank wear recognition". *The International Journal of Advanced Manufacturing Technology*, 1998, 14 (2):77-84. doi:10.1007/bf01322215
10. Jantunen, E., "A summary of methods applied to tool condition monitoring in drilling". *International Journal of Machine Tools and Manufacture*, 2002, 42 (9):997-1010. doi: http://dx.doi.org/10.1016/S0890-6955(02)00040-8
11. Teti, R., Jemielniak, K., O'Donnell, G., Dornfeld, D., "Advanced monitoring of machining operations". *Cirp Ann-Manuf Techn* 2010, 59 (2):717-739. doi:DOI 10.1016/j.cirp.2010.05.010
12. Ghalambaz, M., Shahmiri, M., Kharazi, Y. H. K., "Neural network prediction of the effect of semisolid metal (SSM) processing parameters on particle size and shape factor of primary α -Al aluminum alloy A356.0". *Iranian Journal of Materials Science & Engineering*, 2007, 4 (1):41-47
13. Shahbazi, B., Rezai, B., Chehreh Chelgani, S., Koleini, SMJ, Noaparast, M., "Estimation of gas holdup and input power in froth flotation using artificial neural network". *Iranian Journal of Materials Science & Engineering*, 2015, 12 (1):12-19
14. Zuperl, U., Balic, F. C. J., "Intelligent cutting tool condition monitoring in milling". *Journal of Achievements in Materials and Manufacturing Engineering*, 2011, 49 (2):477-486
15. Salimi, A., Zadshakoyan, M., Ozdemir, A., Seidi, E., "Drill wear prediction system using of motor current and fuzzy logic method". *Iranian Journal of Materials Science & Engineering*, 2012, 9 (2):15-29
16. Amrita Sarkar, G., Sa, U. C. S., "Application of fuzzy logic in Transport planning". *International Journal on Soft Computing*, 2012, 3 (2):1-21
17. Sharma, V., Sharma, S. K, Sharma, A., "Cutting tool wear estimation for turning". *Journal of Intelligent Manufacturing*, 2008, 19 (1):99-108. doi:10.1007/s10845-007-0048-2
18. Leung, R. W. K., Lau, H. C. W, Kwong, C. K. , "An expert system to support the optimization of ion plating process: an OLAP-based fuzzy-cum-GA approach". *Expert Systems with Applications*, 2003, 25 (3):313-330. doi: http://dx.doi.org/10.1016/S0957-

4174(03)00071-X

19. Chandrasekaran, M., Muralidhar, M., Krishna, C. M., Dixit, U. S. "Application of soft computing techniques in machining performance prediction and optimization: a literature review". *The International Journal of Advanced Manufacturing Technology*, 2010, 46 (5-8):445-464. doi:10.1007/s00170-009-2104-x
20. Hashmi, K., Graham, I. D., Mills, B. "Data selection for turning carbon steel using a fuzzy logic approach". *Journal of Materials Processing Technology*, 2003, 135 (1):44-58. doi:10.1016/s0924-0136(02)01011-7